

E-TEX

Engineering Textile

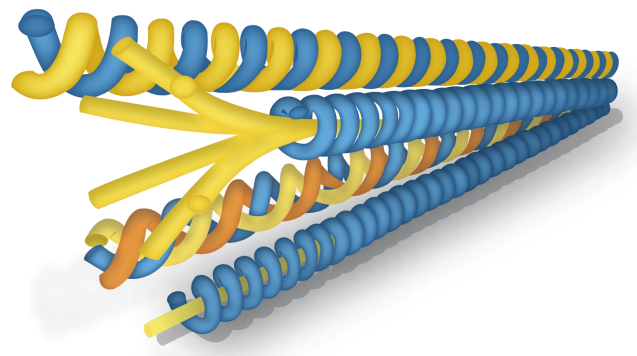

DTF



Combined Two for One Twister
with **Heater**

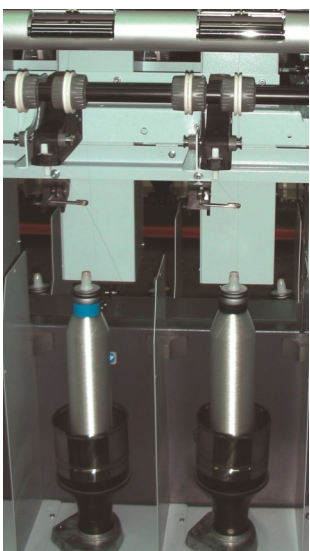

Genuine Parts Service



DTF Combined Two for One Twister with Heater

Highly flexible twister with heater twisting advanced technical yarn constructions

MAIN BENEFITS

- Very broad spectrum of application in two for one twisting with heating process
- Flexible winder suitable for cylindrical or biconical wounded package
- Wide possibilities on the same machine: two for one twisting only, with combined heating
- Easy remote access through your intranet or wireless (with electronic headstock design)
- Tailor made design possibility
- Genuine Parts Service aims to achieve optimized solutions...everywhere, everytime!

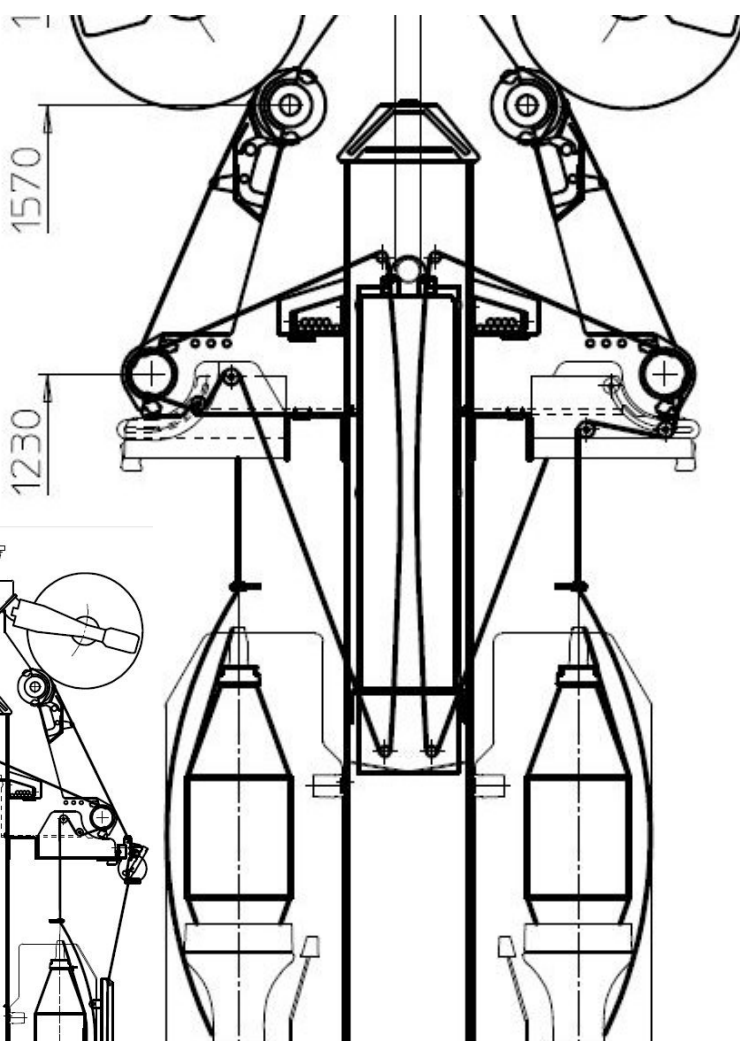

GENERAL FEATURES

Max. spindle nb.	144/120/100
Spindle gauge (mm)	260/325/390
Maximum section	10
Section length (mm)	2080/1950
Maximum length (m)	19.6
Machine width (mm)	900
Delivery speed (m/min)	130
Twist (tpm)	90 to 1500

SUPPLY

Type	Cardboard cylindrical, milk bottle, flanged bobbin
Yarn count (Dtex)	44 to 940
Max. bobbin diam. (mm)	135/150
Maximum weight (Kg)	3.8

SPINDLE

Drive	E-saving Tangential belt
Yarn break sensor	Pneumatic
Maximum speed (rpm)	14000

HEATER / TAKE UP

Maximum diameter (mm)	250
Package traverse (mm)	200/250 on cardboard cylindrical tube
Maximum weight (Kg)	4
Heater length (mm)	500/1000

OPTIONS

Electronic touch screen PLC; oiling; direct cabling; 1 meter length heater; ultra high quality ceramics; soft package

Contact us

8 Allée des MURIERS—BP 80201
07502 GUILHERAND GRANGES
FRANCE



+33 (0) 4 75 86 07 58



www.e-tex.fr



contact@e-tex.fr

The data and illustrations in this brochure refer to the date of printing. E-TEX reserves the right to make any necessary changes at any time and w/o any special notice. Photos: E-TEX. Printed in France, July 2018