

E-TEX

Engineering Textile

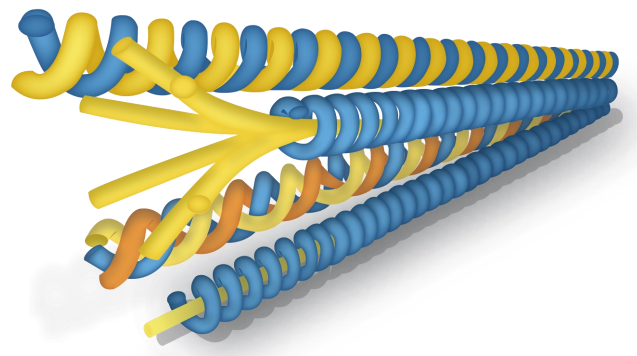

DT326E

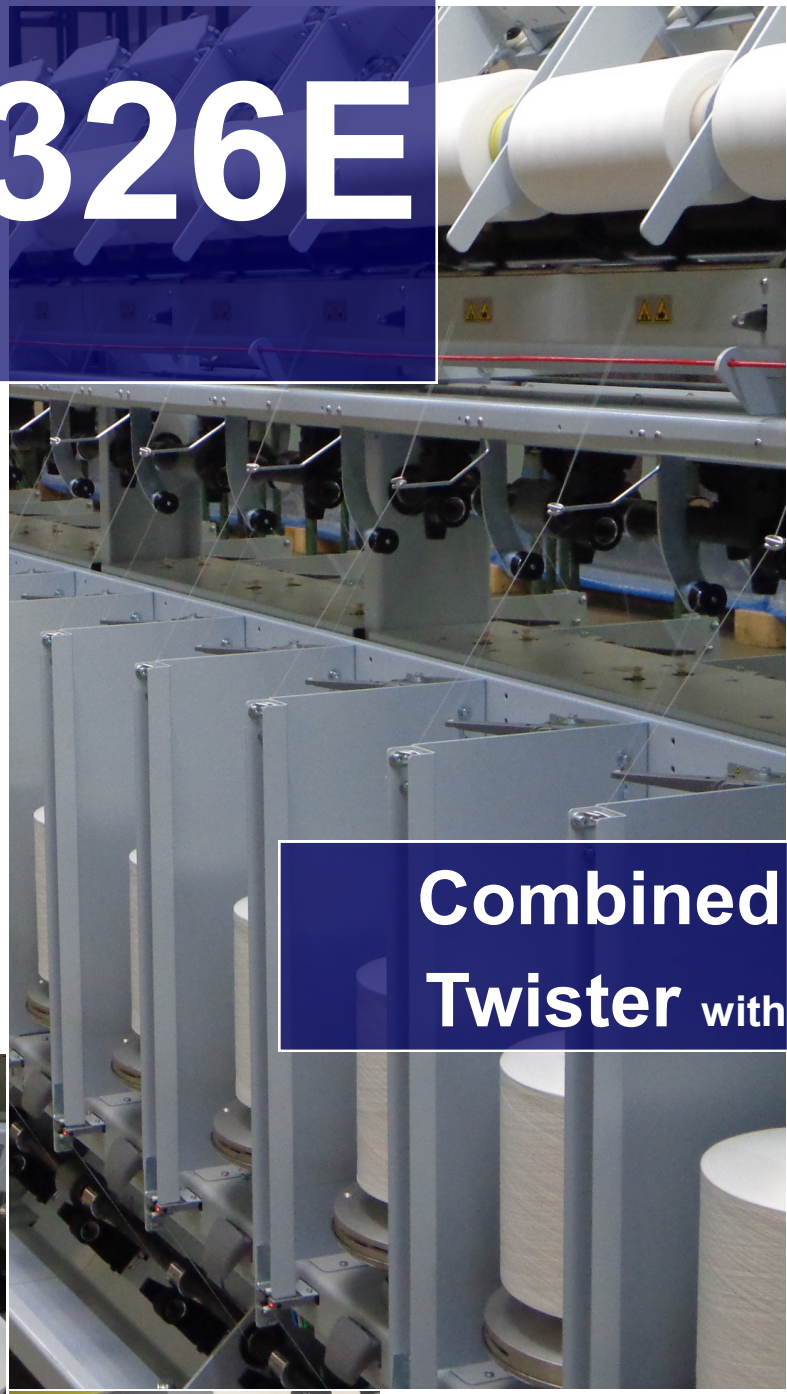

**Combined Two for One
Twister with Heater**



Genuine Parts Service



DT326E Combined Two for One Twister with Heater

Highly flexible twister with heater twisting advanced technical yarn constructions

MAIN BENEFITS

- Very broad spectrum of application in two for one twisting with heating process
- Flexible winder suitable for cylindrical wounded package
- Wide possibilities on the same machine: two for one twisting only, with combined heating
- Easy remote access through your intranet or wireless (with electronic headstock design)
- Tailor made design possibility
- Genuine Parts Service aims to achieve optimised solutions...everywhere, everytime!

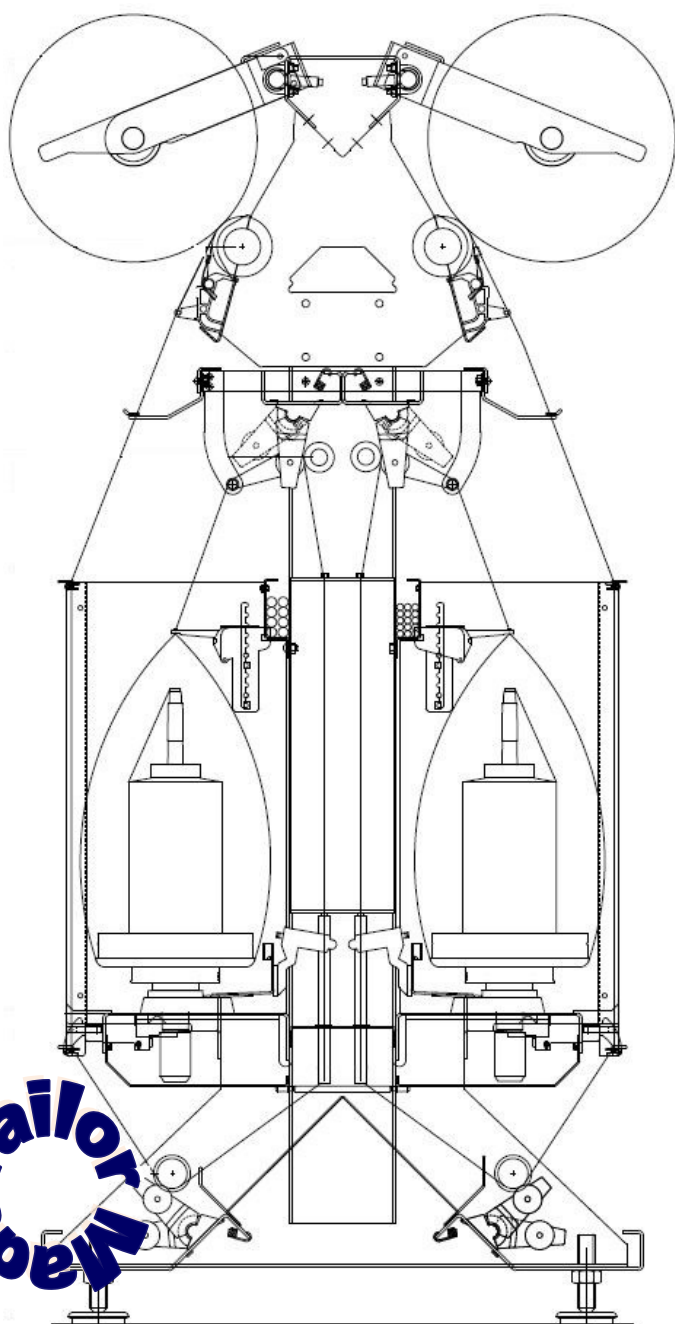

Made Tailor

GENERAL FEATURES

Maximum spindle number	120
Spindle gauge (mm)	325
Maximum section	10
Section length (mm)	1950
Maximum length (m)	21.7
Machine width (mm)	900
Delivery speed (m/min)	180
Twist (tpm)	80 to 800

SUPPLY

Type	Cardboard cylindrical
Yarn count (Dtex)	78 to 330
Max. bobbin diam. (mm)	220/250
Maximum weight (Kg)	5
Traverse (mm)	200/250

SPINDLE

Drive	E-saving Tangential belt
Yarn break sensor	Electronic
Maximum speed (rpm)	9000

HEATER / TAKE UP

Max. diameter (mm)	370/250
Package traverse (mm)	200/250
Tube	MUFF or tube dyeing
Heater length (mm)	500

OPTIONS

Electronic touch screen PLC; one meter length closed electrical heater; ultra high quality ceramics; biconical wounded package; spindle pot

Contact us

8 Allée des MURIERS—BP 80201
07502 GUILHERAND GRANGES

FRANCE



+33 (0) 4 75 86 07 58



www.e-tex.fr



contact@e-tex.fr

The data and illustrations in this brochure refer to the date of printing. E-TEX reserves the right to make any necessary changes at any time and w/o any special notice. Photos: E-TEX. Printed in France, July 2018