

E-TEX

Engineering Textile

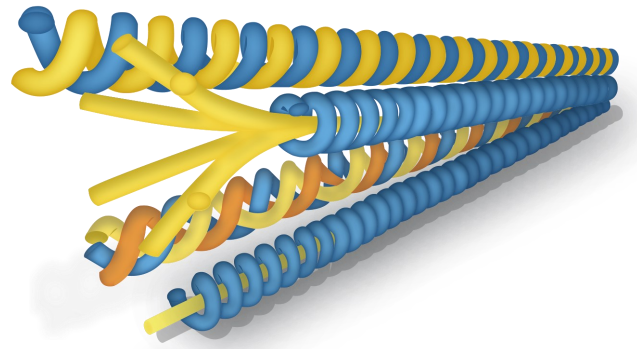

DT360
DT360E

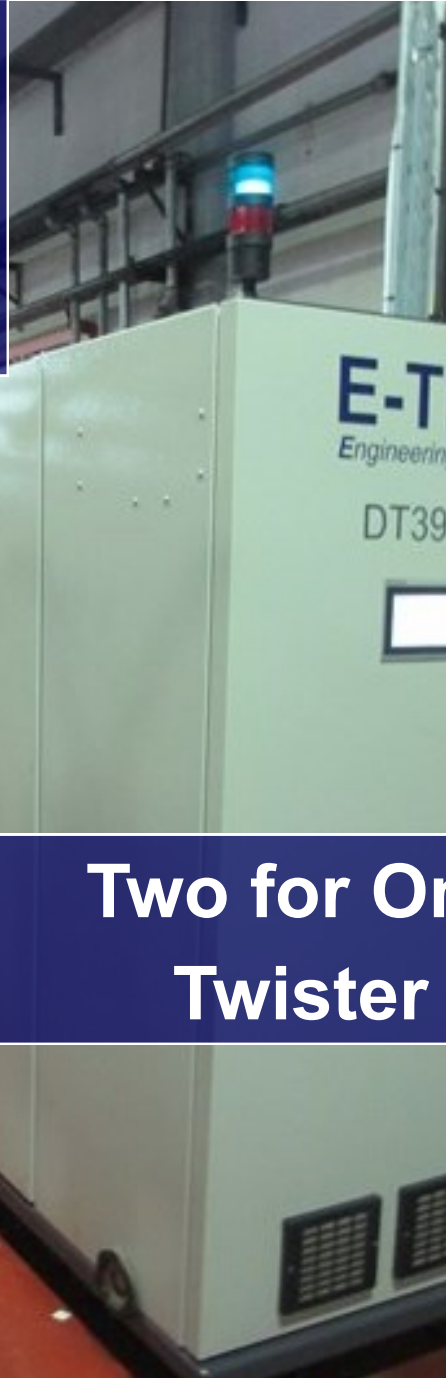

Two for One
Twister

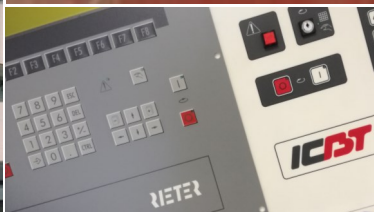

Genuine Parts Service



DT360 / DT360E Two for One Twister

Highly flexible twister producing advanced textile and technical yarn constructions

MAIN BENEFITS

- Very broad spectrum of application in two for one twisting
- Flexible twister suitable for cylindrical or biconical wounded package
- Easy remote access through your intranet or wireless (with electronic headstock design)
- Tailor made design possibility
- Genuine Parts Service aims to achieve optimised solutions...everywhere,

everytime!

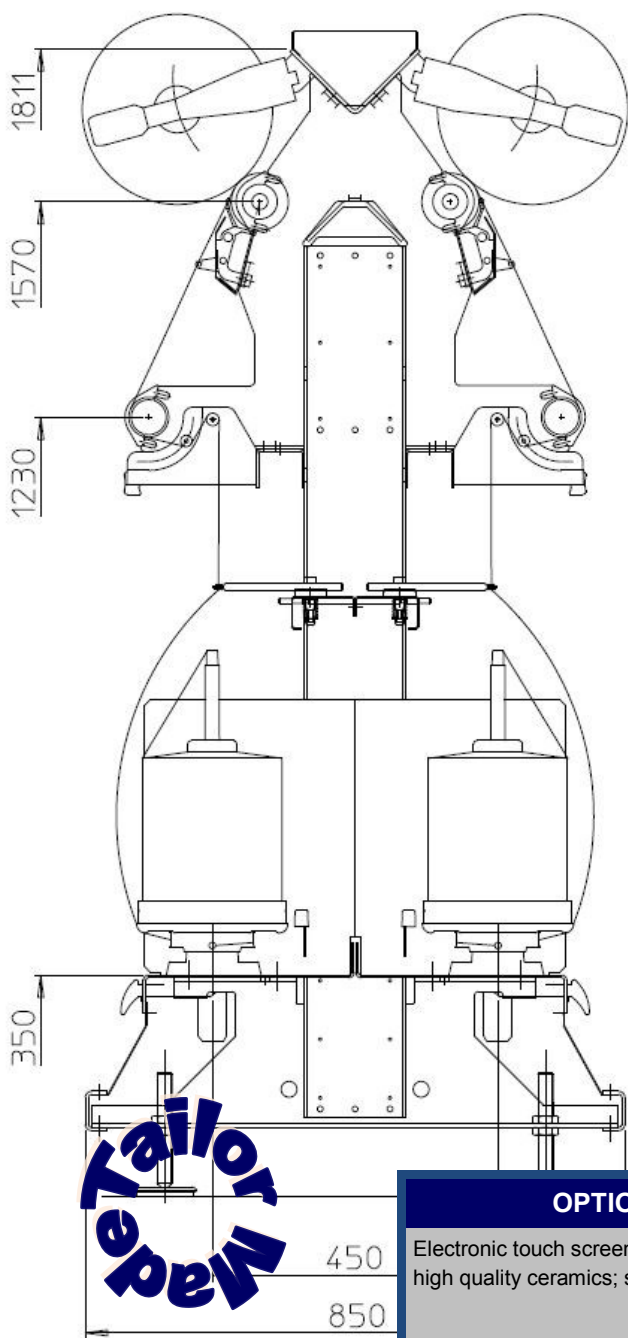

OPTIONS

Electronic touch screen PLC; oiling; ultra high quality ceramics; soft package

GENERAL FEATURES

Spindle type	140/170/235/235/260
Maximum spindle number	160/160/120/100/100
Spindle gauge (mm)	260/260/325/390/390
Maximum section	10
Section length (m)	2.08/2.08/1.95/1.95/1.95
Maximum length (m)	22.9
Machine width (mm)	850
Delivery speed (m/min)	140
Twist (tpm)	60-3500/60-1500/60-1500/60-1500/50-1100

SUPPLY

Type	Pirn/Bobbin
Yarn count (Dtex)	33 - 1000
Pirn length (mm)	305-470/305-470/-/-
Maximum diam. (mm)	135/150/-/-
Weight flat yarn (Kg)	1.6-3/2.2-3.8/-/-
Weight textured yarn (Kg)	1.3-2/1.8-3/-/-
Bobbin traverse (mm)	250
Bobbin weight (mm)	1.2/2/4.5/4.5/5
Maximum bobbin diameter (mm)	135/160/170/220/245

SPINDLE

Drive	E-saving tangential belt
Yarn break sensor	Mechanical
Maximum speed (rpm)	14000/10000/9000/9000/7500

TAKE UP

Maximum diameter (mm)	250
Traverse (mm)	200/200/200/200/250
Optional strokes (mm)	150/150/250/250/200
Tube length (mm)	230/230/230-290/230-290:230-290
Maximum weight (Kg)	3/3/5/5/5

Contact us

8 Allée des MURIERS—BP 80201

07502 GUILHERAND GRANGES

FRANCE



+33 (0) 4 75 86 07 58



www.e-tex.fr



contact@e-tex.fr

The data and illustrations in this brochure refer to the date of printing. E-TEX reserves the right to make any necessary changes at any time and w/o any special notice. Photos: E-TEX. Printed in France, July 2018